

MERSEN
Expertise, our source of energy

OPERATION AND
MAINTENANCE MANUAL

FUSIBLE
SHUNT TRIP
SWITCH



Fusible Shunt Trip Switch

Device Overview	2
Installation Instructions	3
Catalog Number Selection Table.....	4
Motor Fuse Selection Table.....	5
Wiring Diagram - 120VAC Control Interface.....	6
Wiring Diagram - 24V (AC or DC) Control Interface	7
Torque Specifications.....	8
Maintenance	9
Warranty.....	9
FAQs (Frequently Asked Questions)	9
Spare Parts List	10

DEVICE OVERVIEW

Fusible shunt trip disconnect switches are a required safety feature in many industrial and commercial applications. Main branch-circuit fuses provide overcurrent protection in the event of short-circuits, power surges, damage to electrical wiring, etc...by interrupting faulty circuitry and removing it from the electrical system. In addition, the molded case switch can disconnect power from the source prior to known electrical disturbances, before the fuse is required to operate. Integrated into the molded case switch is an electromagnet (shunt trip coil), controlling a spring-loaded conductive strip which maintains continuity between the

line side and load side terminals of the switch. The electromagnetic coil is normally connected to a safety system, such as a fire alarm or smoke detector housed in the surrounding building. Should there be an electrical emergency, a signal is sent to the coil (via the safety system, alarm, sprinkler, etc.) and the electromagnet would be engaged, throwing the switch and disconnecting power. Power can only then be reenergized by manually operating the molded case switch. SPD is also offered as a standard option to protect sensitive elevator circuits and meet requirements for NEC 620.51(E).



INSTALLATION INSTRUCTIONS

DANGER AND WARNING LABELS

UL LISTING INFORMATION

Step 1: Disconnect power from the circuit where the fusible shunt trip switch will be installed. Mount the panel. Wire up the line side three phase conductors into the three line side terminals of the molded case switch (L1, L2 and L3). Wire the load side to the three load side terminals of the class J fuseholder (T1, T2 and T3).

Step 2: Wire the remote control elements to the specified terminal blocks shown in the wiring diagrams on page 6 and 7 (120VAC and 24VAC/DC respectively) of this manual. For 120VAC, safety system controls must supply a set of dry (no voltage) contacts. For 24VAC/DC, safety system controls must provide the voltage source.

Step 3: Connect power to the circuit on which the fusible shunt trip disconnect switch is installed. Test the shunt trip operation. Close the molded case switch manually; the pilot light (if installed) indicating that the switch is closed will indicate. Engage the key switch (if installed) to activate the shunt trip and trip the molded case switch. The switch will trip and the pilot light will turn off.



CATALOG NUMBER SELECTION TABLE

ES SERIES - FUSIBLE SHUNT TRIP DISCONNECT SWITCH

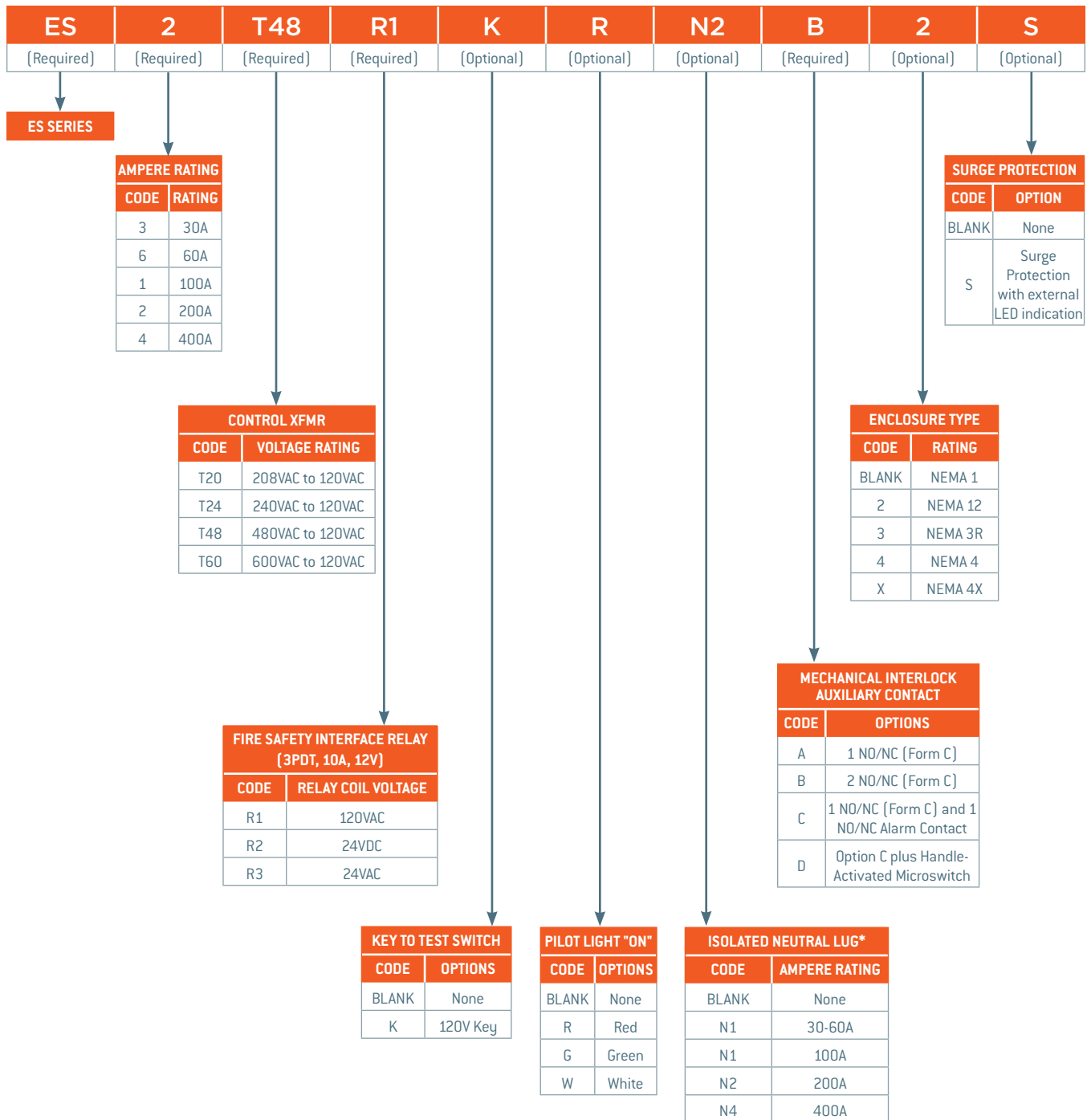

- Fire Alarm Voltage Monitoring Relay included in all Mersen offerings. No additional part suffixes required. (Competitor Options F1 and F3).
- SPD is offered as 75kA pluggable unit for easy replacement and includes standard front panel end of life indication.

*Neutral lug rating should be greater than or equal to the switch ampere rating. For 200% lug over sizing, select next higher rating. N4 is suitable for 200% over sizing at 400A.

MAIN POWER FUSE (MOTOR FUSE) SELECTION TABLE

Motor HP	Recommended Class J (AJT series) Fuse Ampere Rating based on Motor Acceleration Characteristics											
	208V			240V			480V			600V		
	Min.	Typical	Heavy	Min.	Typical	Heavy	Min.	Typical	Heavy	Min.	Typical	Heavy
1/2	3	3-1/2	4-1/2	3	3-1/2	4	1-1/2	1-6/10	2	1-1/4	1-1/2	1-6/10
3/4	4-1/2	5	6-1/4	4	5	6	2	2-1/4	2-8/10	1-6/10	2	2-8/10
1	6	7	9	5	6-1/4	8	2-1/2	3-2/10	4	2-1/4	2-8/10	3-1/2
1-1/2	8	10	12	8	9	12	3-1/2	4-1/2	5-6/10	3	3-1/2	4-1/2
2	9	12	15	8	10	12	4	5	6	3-2/10	4	5
3	15	15	20	12	15	17-1/2	6	7	9	5	6	7
5	20	25	30	20	25	30	10	12	15	8	10	12
7-1/2	30	35	45	30	35	40	15	17-1/2	20	12	15	17-1/2
10	40	50	60	35	40	50	17-1/2	20	25	15	17-1/2	20
15	60	70	90	50	60	80	25	30	40	20	25	30
20	80	90	110	70	80	100	35	40	50	30	35	40
25	90	110	150	80	100	125	40	50	60	35	40	50
30	110	150	175	100	125	150	50	60	70	40	50	60
40	150	175	200	125	150	200	70	80	100	50	60	80
50	175	225	300	175	200	250	80	100	125	70	80	100
60	200	250	300	200	225	300	100	125	150	80	90	110
75	250	350	400	250	300	350	125	150	175	100	125	150
100	350	400	-	300	350	-	175	200	225	125	150	175
125	-	-	-	400	-	-	200	225	300	175	200	225
150	-	-	-	-	-	-	225	250	350	175	225	300
200	-	-	-	-	-	-	300	350	-	250	300	350
250	-	-	-	-	-	-	400	-	-	300	350	-
300	-	-	-	-	-	-	-	-	-	350	-	-

Minimum – This sizing is recommended if motor acceleration time does not exceed 2 seconds. Minimum sizing with class J fuses will provide overload relay back up protection but may not coordinate with some NEMA Class 20 overload relays. Minimum sizing is generally not heavy enough for motors with code letter G or higher.

Typical – Suggested for most applications. Will coordinate with NEMA Class 20 overload relays. Suitable for motor acceleration times up to 5 seconds

Heavy – Maximum allowable fuse size when an overload relay or motor thermal protector is included in the branch circuit. If this fuse size is not sufficient to start the load, class J time-delay fuses may be increased to a maximum of 225% of full load amperes. Suggested for Design E and high efficiency Design B motors.

WIRING DIAGRAM - 120VAC CONTROL INTERFACE

-LEGEND-

N.O./F.A. CONTACT: CONTACT SUPPLIED FROM THE FIRE ALARM SYSTEM TO INITIATE THE SHUNT TRIP.
SHUNT TRIP: SOLENOID THAT REMOTELY TRIPS THE SWITCH AND IS ACTIVATED BY THE CLOSING OF THE FIRE ALARM CONTACT OR KEY TEST SWITCH.
CR: CONTROL RELAY USED TO ISOLATE THE REMOTE CONTACT FROM THE SHUNT TRIP.
FR: RELAY USED TO MONITOR THE VOLTAGE IN THE SWITCH FROM A REMOTE LOCATION.
PL: PILOT LIGHT THAT INDICATES CONTROL VOLTAGE ON THE OUTSIDE OF THE ENCLOSURE.

- INTERNAL CONNECTION POINTS
- CUSTOMER CONNECTION POINTS

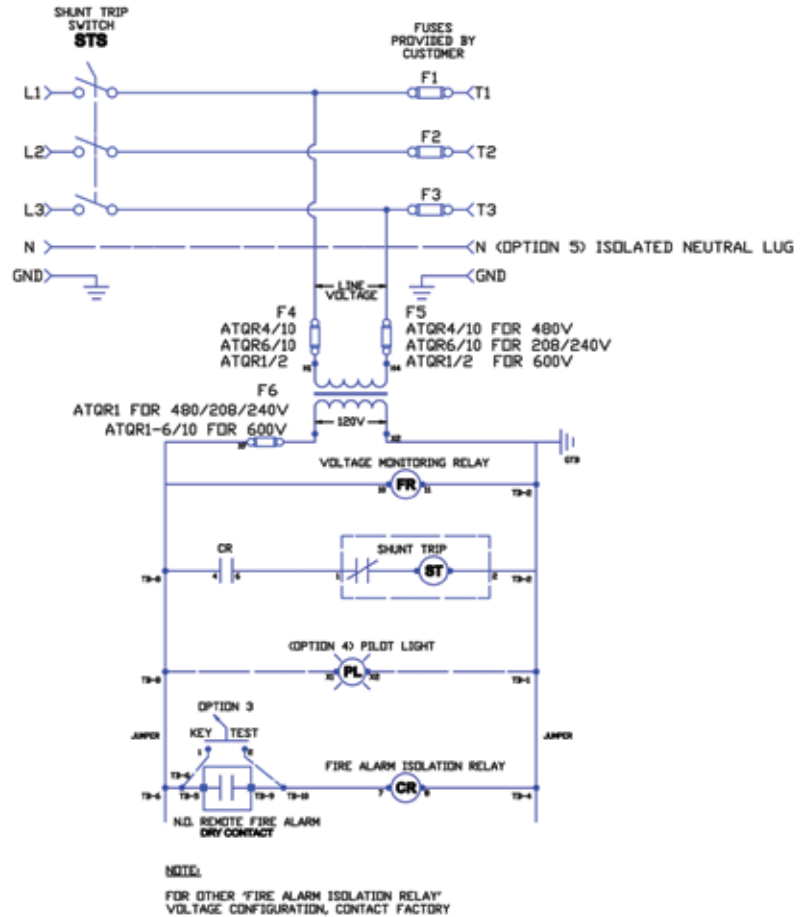
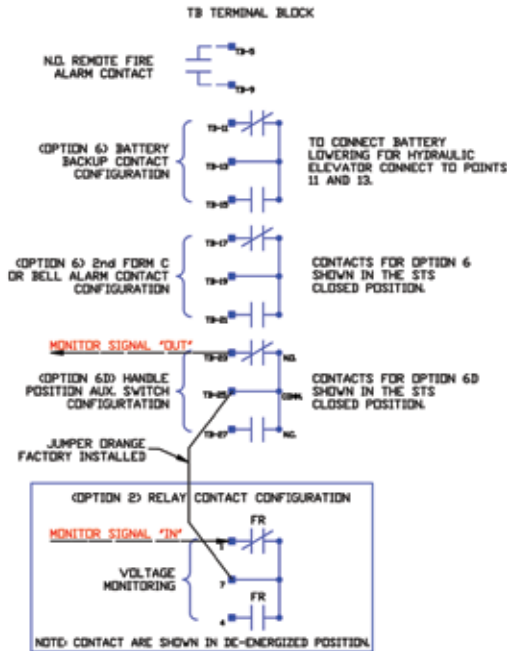

Notes:

1. TB-5 and TB-9 must be dry (no voltage) normally open contacts from safety system
2. If a surge protection option is selected, it will be connected line to ground between the STS and fuses F1-F3

WIRING DIAGRAM - 24V (AC OR DC) CONTROL INTERFACE

-LEGEND-

N.O./F.A. CONTACT: CONTACT SUPPLIED FROM THE FIRE ALARM SYSTEM TO INITIATE THE SHUNT TRIP.
SHUNT TRIP: SOLENOID THAT REMOTELY TRIPS THE SWITCH AND IS ACTIVATED BY THE CLOSING OF THE FIRE ALARM CONTACT OR KEY TEST SWITCH.
CR: CONTROL RELAY USED TO ISOLATE THE REMOTE CONTACT FROM THE SHUNT TRIP.
FR: RELAY USED TO MONITOR THE VOLTAGE IN THE SWITCH FROM A REMOTE LOCATION.
PL: PILOT LIGHT THAT INDICATES CONTROL VOLTAGE ON THE OUTSIDE OF THE ENCLOSURE.

- INTERNAL CONNECTION POINTS
- CUSTOMER CONNECTION POINTS

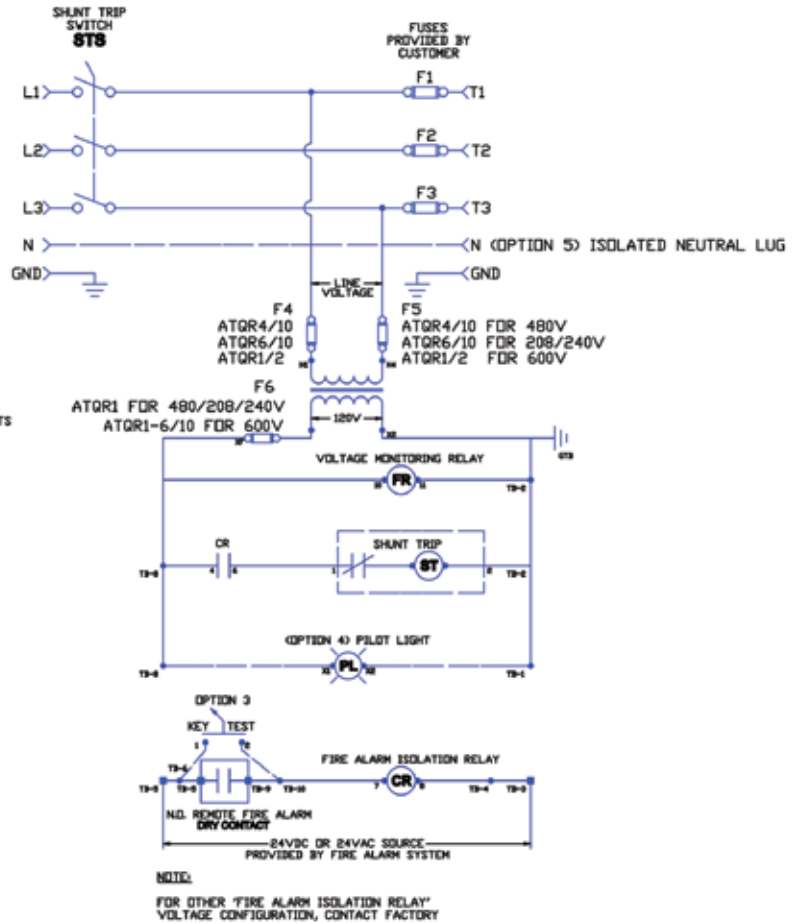
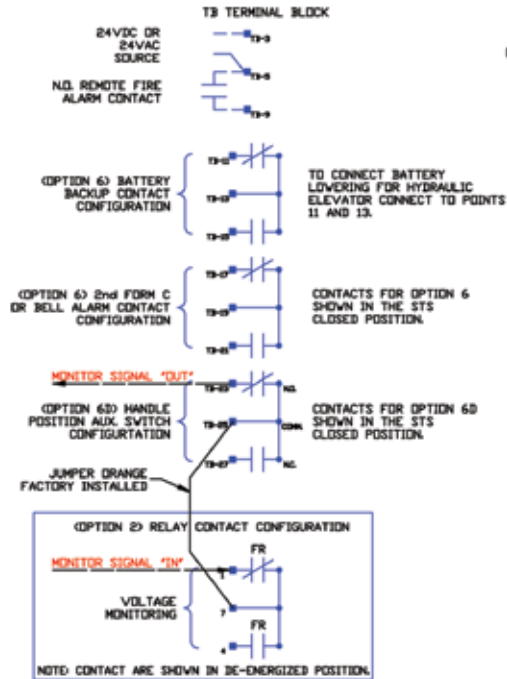

Notes:

- For 24VAC control systems, 24VAC must be connected between TB-5 and TB-3. For 24VDC control systems, 24VDC must be connected between TB-5 and TB-3. Do not source AC voltage into a DC control system or vice versa.
- If a surge protection option is selected, it will be connected line to ground, between the STS and fuses F1-F3.

TORQUE SPECIFICATIONS

Line Side Wire Connections (Molded Case Switch)

Amp Rating	Wire Size	Tightening Torque
30, 60, 100	10 AWG	20 in-lb
	8 AWG	36 in-lb
	6 – 4 AWG	45 in-lb
	3 AWG	50 in-lb
	2 – 1/0	60 in-lb
200	6 – 350kcmil (Cu)	375 in-lb
	4 – 350kcmil (Al)	
400	3/0 – 500kcmil (Cu)	300 in-lb
	4/0 – 500kcmil (Al)	

Load Side Wire Connections (Class J Fuseholder)

Amp Rating	Wire Size	Tightening Torque
30	14 – 2 AWG	35 in-lb
60	14 – 2 AWG	45 in-lb
100	6 – 1/0	100 in-lb (Al)
		60 in-lb (Cu)
200	6 – 350kcmil	375 in-lb
400	4 – (2) 350kcmil	275 in-lb

Neutral Lug Connections

Wire Size	Torque
14 – 8 AWG	50 in-lb
2/0	120 in-lb
6 – 350kcmil	275 in-lb
500kcmil	500 in-lb

Grounding Lug Connections

Wire Size	Torque
14 – 10 AWG	35 in-lb
8 AWG	40 in-lb
6 – 4 AWG	45 in-lb
2 – 1/0	50 in-lb

Terminal Block Connections

Wire Size	Torque
22 – 10 AWG	4.4 – 8.8 in-lb

MAINTENANCE AND WARRANTY

MAINTENANCE

The following preventative maintenance measures should be considered in order to maintain product integrity

- Periodically clean product exterior and interior to remove any dust, particles, tools or other. Follow proper safety precautions when performing maintenance.
- Periodically check lug torque values in order to maintain product specifications. Recommended torque values for all parts are shown on page 8 of this manual. Follow proper safety precautions when performing maintenance.
- Preventative maintenance may include thermal-scan imaging in order to identify any “hot-spots” or generation of excessive heat. Any temperature increase, not related to load variations or ambient temperature could signal a problem with lug torque.
- Maximum temperature at any lug should never exceed 75°C under any conditions.

WARRANTY

Mersen warrants to the buyer that products and any services furnished hereunder will be free of defects in material, workmanship and will be of the kind and quality specified in Mersen standard terms and conditions. The foregoing shall apply only to failure to meet said warranties (excluding any defects in title), which appear within 1 year from the date of delivery to the customers site. All other non-Mersen manufactured components used in the fabrication of Mersen equipment shall be covered by their respective manufacturers' warranties.

FREQUENTLY ASKED QUESTIONS

Q: If I accidentally order the Fusible Shunt Trip Switch with a wrong component or my job parameters have changed, can the component be changed in the field?

A: Unfortunately the answer is NO. To comply with UL guidelines, product modifications can only be completed by authorized factory personnel. Other modifications will void the Mersen warranty and UL listing.

Q: Are the units tested before they leave the factory?

A: YES. Mersen tests and documents every unit that leaves the factory floor. A shunt trip switch inspection report is included within every unit.

Q: What is the shipping method and typical weights of a unit?

A: All units are shipped on pallets via truck. Unit weight varies depending upon ampere rating from approximately 70 pounds up to 200 pounds each.

Q: Why do the fuses on the control transformer keep opening?

A: The safety system normally open contacts (connection between TB-5 and TB-9) are likely supplying voltage. Check to ensure that there is no voltage present.

Q: Is there a technical support number I can call for assistance?

A: YES. Mersen offers live technical support from 8:00AM to 6:30PM EST. Call (978) 465-4853 for assistance, or email technicalservices.nby@mersen.com.

SPARE PARTS LIST

Mersen #	Mfg Part #	Description
440104	ED63S100A	100A Molded Case Switch
440026	S01ED62A	100A Molded Case Switch Assembly Option A
440027	S01ED62AA	100A Molded Case Switch Assembly Option B
440028	S01ED62AB	100A Molded Case Switch Assembly Option C
440067	FXD63S250A	250A Molded Case Switch
440063	S01FD60	Shunt Trip Mechanism for 250A Molded Case Switch, 120VAC Coil
440064	A01FD64	Auxiliary Contact, Option A, 250A Switch Assembly
440065	A02FD64	Auxiliary Contact, Option B, 250A Switch Assembly
440066	C01FD64	Auxiliary Contact, Option C, 250A Switch Assembly
440097	JXD63S400A	400A Molded Case Switch
440099	S01JLD62A	Auxiliary Contact, Option A, 400A Switch Assembly
440100	S01JLD62A + A01JLD64	Auxiliary Contact, Option B, 400A Switch Assembly
440101	S01JLD62A + B01JLD64	Auxiliary Contact, Option C, 400A Switch Assembly
330458	CRHOH	ROTARY DOOR MOUNTED OPERATING HANDLE NEMA 1, 12
330478	RHOH	ROTARY DOOR MOUNTED OPERATING HANDLE NEMA 3R (for all plus NEMA 12 for only 200A SW)
330616	RHOH4	'ROTARY DOOR MOUNTED OPERATING HANDLE NEMA 4 & 4x
330494	RHOSVD	ROTARY DOOR MOUNTED OPERATOR SHAFT
330459	RHOEBO	ED 100A FRAME ROTARY DOOR MOUNTED MOLDED CASE BREAKER SWITCH OPERATOR
330477	RHOFBO	FD 250A FRAME ROTARY DOOR MOUNTED MOLDED CASE BREAKER SWITCH OPERATOR
330615	RHOJBO	JD 400A FRAME ROTARY DOOR MOUNTED MOLDED CASE BREAKER SWITCH OPERATOR
440102	LY2N-AC110/120	DPDT, 10A SWITCHING PLUG-IN/SOLDER, LED (R1 OPTION)
440072	LY2N-AC24	DPDT, 10A SWITCHING PLUG-IN/SOLDER, LED (R3 OPTION)
440071	LY2N-DC24	DPDT, 10A SWITCHING PLUG-IN/SOLDER, LED (R2 OPTION)
440070	LY3N-AC110/120	3PDT, 10A SWITCHING, PLUG-IN/SOLDER, LED (OLD REF. 700-33A1)
440083	A22K-2AL-11	KEY SELECT, MOMENTARY, 2 NOTCH, 1A1B, ASSEMBLED
440084	M22-FW-T1	INDICATOR, FLAT, ROUND,WHITE, 110VAC ASSEMBLED
440086	M22-FG-T1	INDICATOR, FLAT, ROUND,GREEN, 110VAC ASSEMBLED
440085	M22-FR-T1	INDICATOR, FLAT, ROUND,RED, 110VAC ASSEMBLED
440087	M22-FY-T1	INDICATOR, FLAT, ROUND,YELLOW, 110VAC ASSEMBLED
440031	M49750T	MARCUS TRANSFORMER 208, 240, 480V TO 120V
440103	M0150V	MARCUS TRANSFORMER 600V TO 120V
440068	HAS-1	HANDLE OPERATED MICROSWITCH FOR ASSEMBLY OPTION D



MERSEN IS A GLOBAL EXPERT
IN ELECTRICAL POWER AND
ADVANCED MATERIALS

NORTH AMERICA

USA
Mersen USA
374 Merrimac Street
Newburyport, MA 01950
T : 978 462 6662

CANADA
Mersen Canada
6200 Kestrel Road
Mississauga, ON L5T 1Z1
T : 416 252 9371

EUROPE

FRANCE
Mersen France SB S.A.S.
15 rue Jacques de Vaucanson
F-69720 Saint-Bonnet-de-Mure
T : +33 4 72 22 66 11

ASIA

CHINA
Mersen Shanghai
No.55-A6. Shu Shan Road
Songjiang 201611 Shanghai
T : +8621 67602388



EP.MERSEN.COM